



P3 SERIES 3 WATT PROPORTIONAL HV DC/DC CONVERTERS

FEATURES

- ▶ **Customer Selects Output Voltage**
- ▶ Single Outputs to + or - 6000 Vdc
- ▶ Dual Outputs to +/- 3000 Vdc
- ▶ High Reliability
- ▶ Industry Standard Pinouts
- ▶ Wide Temperature Range (-20 to +85°C)
- ▶ 60 kHz Switching Frequency
- ▶ 6500 Vdc Output Isolation
- ▶ Continuous Short Circuit Protection



The P3 Series of miniature DC/DC converters offers a 6500 Vdc isolated high voltage output directly proportional to input voltage. They are available in alternate industry standard pinouts. All models will tolerate a short circuit indefinitely. They also include a LC input filter to minimize reflected ripple current.

ELECTRICAL SPECIFICATIONS

| | | | |
|------------------------|--------------|----------------------------------|-----------------|
| Voltage Accuracy | +/-10% | Input Filter | LC Input Filter |
| Line Regulation | Proportional | Efficiency | 70% (typ.) |
| Load Regulation | +/- 10% | Short Circuit Protection | Continuous |
| Output Ripple | < 1% P-P | Switching Frequency | 60 kHz |
| Startup Voltage | < 0.7Vdc | Output Isolation | 6500 Vdc |
| | | Input / Output Capacitance | < 30pF |

GENERAL SPECIFICATIONS

| | | | |
|--------------------------------|---------------------------|----------------|---|
| Temp. Stability | +/-0.02%/°C | EMI/RFI | Shielded Version Available (<i>Suffix /S</i>) |
| Temp. (Operating , Case) | -20 to +85°C | Derating | None |
| Temp. (Storage) | -55 to +100°C | Cooling | Free-Air Convection |
| Humidity | 0 to 95% (Non-Condensing) | | |

PHYSICAL SPECIFICATIONS

| | | | |
|------------------|-------------------------|---------------------|----------------|
| Dimensions | 1.5 x 2.4 x 0.81 inches | Case Material | Black Phenolic |
| Weight | 3.1 Oz | | |



P3 SERIES 3 WATT PROPORTIONAL HV DC/DC CONVERTERS

SINGLE OUTPUTS

| REPRESENTATIVE MODEL LISTING | | | | | | | |
|------------------------------|----------|----------------------|---------|-----------|-----------------------|--------------------|---------|
| MODEL NUMBER | | INPUT SPECIFICATIONS | | | OUTPUT SPECIFICATIONS | | |
| Non-RoHS | RoHS | VOLTAGE | NO LOAD | FULL LOAD | VOLTAGE | RIPPLE | CURRENT |
| P3-10 | P3-10/Y | 0V - 12Vdc | <175 mA | <333 mA | 0V- 100Vdc | <0.5% (0.5V p-p) | 30 mA |
| P3-20 | P3-20/Y | 0V - 12Vdc | <125 mA | <333 mA | 0V- 200Vdc | <0.25% (0.5V p-p) | 15 mA |
| P3-25 | P3-25/Y | 0V - 12Vdc | <125mA | <333 mA | 0V - 250Vdc | <0.2% (0.5V p-p) | 12 mA |
| P3-30 | P3-30/Y | 0V - 12Vdc | <125 mA | <333 mA | 0V - 300Vdc | <0.3% (0.9V p-p) | 10 mA |
| P3-50 | P3-50/Y | 0V - 12Vdc | <125 mA | <333 mA | 0V - 500Vdc | <0.02% (0.1V p-p) | 6 mA |
| P3-60 | P3-60/Y | 0V - 12Vdc | <125 mA | <333 mA | 0V- 600Vdc | <0.1% (0.6V p-p) | 5 mA |
| P3-80 | P3-80/Y | 0V - 12Vdc | <125 mA | <333 mA | 0V- 800Vdc | <0.03% (0.24V p-p) | 3.75 mA |
| P3-100 | P3-100/Y | 0V - 12Vdc | <125 mA | <333 mA | 0V- 1kVdc | <0.03% (0.3V p-p) | 3 mA |
| P3-120 | P3-120/Y | 0V - 12Vdc | <125 mA | <333 mA | 0V- 1.2kVdc | <0.02% (0.24V p-p) | 2.5 mA |
| P3-130 | P3-130/Y | 0V - 12Vdc | <150 mA | <333 mA | 0V- 1.3kVdc | <0.2% (2.6V p-p) | 2.3 mA |
| P3-150 | P3-150/Y | 0V - 12Vdc | <150 mA | <333 mA | 0V - 1.5kVdc | <0.05% (0.75 p-p) | 2 mA |
| P3-200 | P3-200/Y | 0V - 12Vdc | <175 mA | <333 mA | 0V- 2kVdc | <0.25% (5V p-p) | 1.5 mA |
| P3-220 | P3-220/Y | 0V - 12Vdc | <175 mA | <333 mA | 0V- 2.2kVdc | <0.25% (5.5V p-p) | 1.36 mA |
| P3-230 | P3-230/Y | 0V - 12Vdc | <175 mA | <333 mA | 0V - 2.3kVdc | <0.25% (5.7V p-p) | 1.3 mA |
| P3-250 | P3-250/Y | 0V - 12Vdc | <175 mA | <333 mA | 0V - 2.5kVdc | <0.25% (6V p-p) | 1.2 mA |
| P3-300 | P3-300/Y | 0V - 12Vdc | <175 mA | <333 mA | 0V - 3kVdc | <0.25% (7V p-p) | 1 mA |
| P3-320 | P3-320/Y | 0V - 12Vdc | <175 mA | <333 mA | 0V - 3.2kVdc | <0.5% (16V p-p) | 0.93 mA |
| P3-330 | P3-330/Y | 0V - 12Vdc | <175 mA | <333 mA | 0V - 3.4kVdc | <0.5% (17V p-p) | 0.9 mA |
| P3-350 | P3-350/Y | 0V - 12Vdc | <175 mA | <333 mA | 0V - 3.5kVdc | <0.5% (17.5V p-p) | 0.85 mA |
| P3-400 | P3-400/Y | 0V - 12Vdc | <175 mA | <333 mA | 0V - 4kVdc | <0.5% (20V p-p) | 0.75 mA |
| P3-500 | P3-500/Y | 0V - 15Vdc | <175 mA | <390 mA | 0V - 5kVdc | <0.5% (25V p-p) | 0.6 mA |
| P3-600 | P3-600/Y | 0V - 15Vdc | <175 mA | <390 mA | 0V- 6kVdc | <0.5% (30V p-p) | 0.5 mA |



P3 SERIES 3 WATT PROPORTIONAL HV DC/DC CONVERTERS

DUAL OUTPUTS

| REPRESENTATIVE MODEL LISTING | | | | | | | |
|------------------------------|-----------|----------------------|---------|-----------|-----------------------|--------------------|---------|
| MODEL NUMBER | | INPUT SPECIFICATIONS | | | OUTPUT SPECIFICATIONS | | |
| Non-RoHs | RoHs | VOLTAGE | NO LOAD | FULL LOAD | VOLTAGE | RIPPLE | CURRENT |
| P3-D5 | P3-D5/Y | 0V - 12Vdc | <175 mA | <333 mA | 0V - +/-50Vdc | <0.5% (0.25V p-p) | 30 mA |
| P3-D10 | P3-D10/Y | 0V - 12Vdc | <125 mA | <333 mA | 0V - +/-100Vdc | <0.25% (0.12V p-p) | 15 mA |
| P3-D15 | P3-D15/Y | 0V - 12Vdc | <125 mA | <333 mA | 0V - +/-150Vdc | <0.3% (0.4V p-p) | 10 mA |
| P3-D25 | P3-D25/Y | 0V - 12Vdc | <150 mA | <333 mA | 0V - +/-250Vdc | <0.02% (0.05V p-p) | 6 mA |
| P3-D30 | P3-D30/Y | 0V - 12Vdc | <175 mA | <333 mA | 0V - +/-300Vdc | <0.1% (0.3V p-p) | 5 mA |
| P3-D40 | P3-D40/Y | 0V - 12Vdc | <125 mA | <333 mA | 0V - +/-400Vdc | <0.03% (0.12V p-p) | 3.75 mA |
| P3-D50 | P3-D50/Y | 0V - 12Vdc | <125 mA | <333 mA | 0V - +/-500Vdc | <0.03% (0.15V p-p) | 3 mA |
| P3-D60 | P3-D60/Y | 0V - 12Vdc | <125 mA | <333 mA | 0V - +/-600Vdc | <0.02% (0.12V p-p) | 2.5 mA |
| P3-D75 | P3-D75/Y | 0V - 12Vdc | <150 mA | <333 mA | 0V - +/-750Vdc | <0.05% (0.37V p-p) | 2 mA |
| P3-D100 | P3-D100/Y | 0V - 12Vdc | <175 mA | <333 mA | 0V - +/-1kVdc | <0.25% (2.5V p-p) | 1.5 mA |
| P3-D150 | P3-D150/Y | 0V - 12Vdc | <175 mA | <333 mA | 0V - +/-1.5kVdc | <0.25% (3.5V p-p) | 1 mA |
| P3-D200 | P3-D200/Y | 0V - 12Vdc | <175 mA | <333 mA | 0V - +/-2kVdc | <0.5% (10V p-p) | 0.75 mA |
| P3-D250 | P3-D250/Y | 0V - 15Vdc | <175 mA | <390 mA | 0V - +/-2.5kVdc | <0.5% (12.5V p-p) | 0.6 mA |
| P3-D300 | P3-D300/Y | 0V - 15Vdc | <175 mA | <390 mA | 0V - +/-3kVdc | <0.5% (15V p-p) | 0.5 mA |

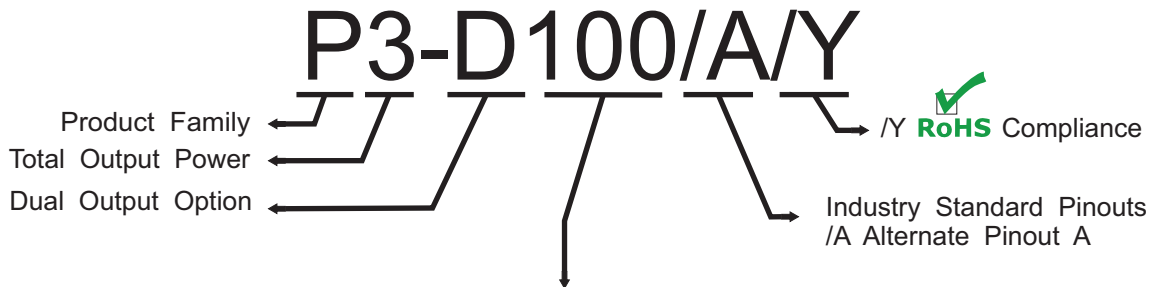

Customer Selects Output Voltage*

The P3 Series are designed such that the customer may order any output voltage from 100Vdc to 6kVdc (Single Outputs) or +/- 50Vdc to +/- 3000Vdc (Dual Outputs) at no additional charge.

***ACTUAL OUTPUT VOLTAGE IS 10X**



P3 SERIES 3 WATT PROPORTIONAL HV DC/DC CONVERTERS

STANDARD & ALTERNATE (/A)

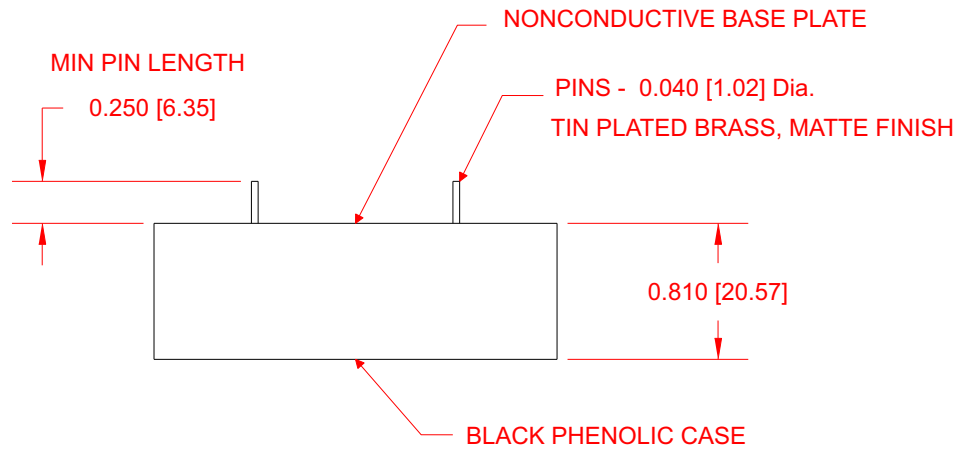
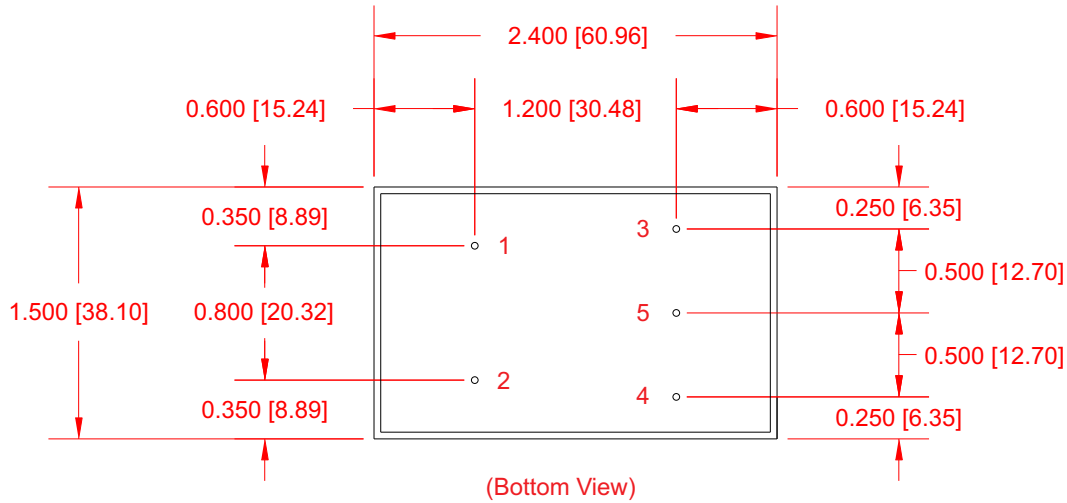

| PIN # | STANDARD | | ALTERNATE (/A) | |
|-------|----------|----------|----------------|----------|
| | Single | Dual | Single | Dual |
| 1 | + Input | + Input | + Input | + Input |
| 2 | - Input | - Input | - Input | - Input |
| 3 | - Output | - Output | +Output | + Output |
| 4 | + Output | + Output | - Output | - Output |
| 5 | No Pin | Com | No Pin | Com |

*Dimensions are in Inches
 [Metric equivalents in brackets]*



P3 SERIES 3 WATT PROPORTIONAL HV DC/DC CONVERTERS

APPLICATION NOTES

INPUT AND OUTPUT IMPEDANCE

The P3 Series of power converters have been designed to be stable with no external capacitors when used in low inductance input and output circuits. However, in some applications, the inductance associated with the distribution from the power source to the input of the converter can affect the stability of the converter. The addition of a 100 μ F electrolytic capacitor with an ESR <1 Ohm across the input helps ensure stability of the converter. In many applications, the user has to use decoupling capacitance at the load.

SHORT CIRCUIT PROTECTION

The P3 Series is equipped with short circuit protection. The converter will fold-back the input power whenever a short circuit is applied to its output and automatically recover after the overload condition is removed.

ISOLATION

The output of the P3 Series is galvanically isolated from the input, capacitance is < 30pF and resistance is > 10G Ohm. For dual output units Isolation is from Com output pin (5) and -Input (2).

RIPPLE AND NOISE

Figure below shows a typical output voltage ripple waveform, measured at full rated load current with no additional output filtering. External low ESR capacitors may be added across output to further reduce ripple.

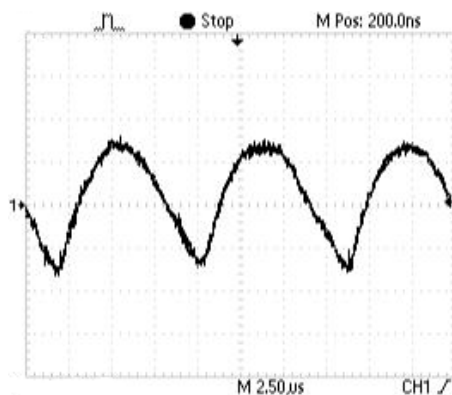

STARTUP TRANSIENT

Figure below shows a typical output voltage during turn-on, measured at no load current with no additional output filtering.

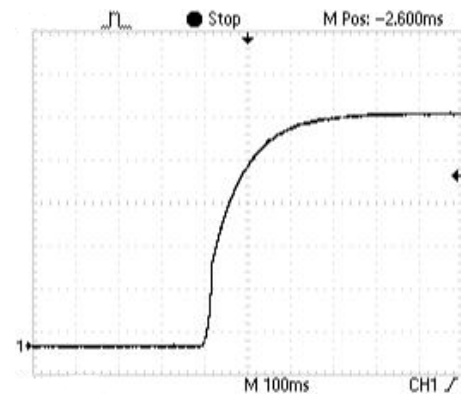
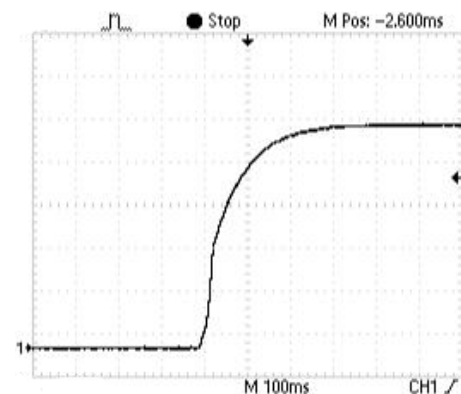

Figure below shows a typical output voltage during turn-on, measured at full rated load current with no additional output filtering.





P3 SERIES 3 WATT PROPORTIONAL HV DC/DC CONVERTERS

APPLICATION NOTES

INRUSH CURRENT

The inrush current of the P3 Series has been kept as low as possible. However, a series resistor may be inserted in the input line to limit this current further.

CONNECTION IN PARALLEL

The figures below shows how to connect outputs of several units with equal nominal output voltage in parallel with the use of oring diodes.

LOAD TRANSIENT

Figure below shows a typical output voltage response, measured during a transition from full rated load current to no load current with no additional output filtering.

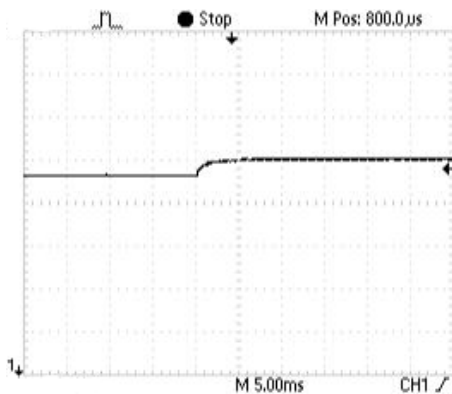
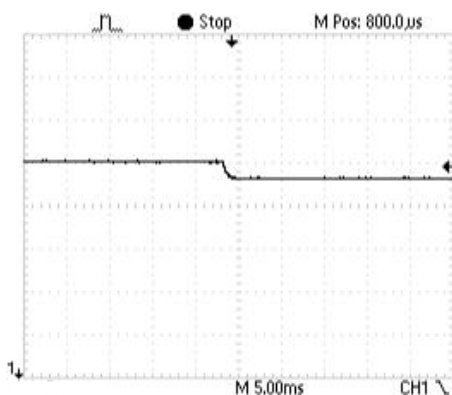
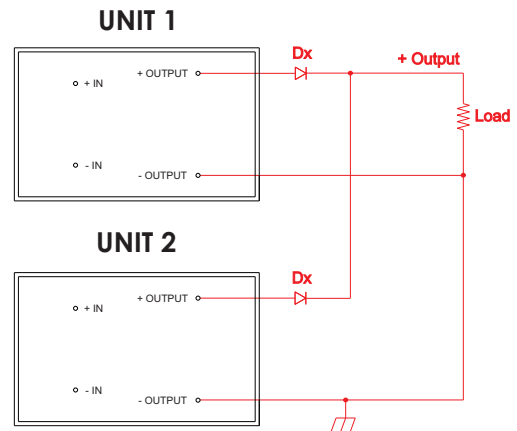

Figure below shows a typical output voltage response, measured during a transition from no load current to full rated load current with no additional output filtering.



POSITIVE OUTPUT



NEGATIVE OUTPUT

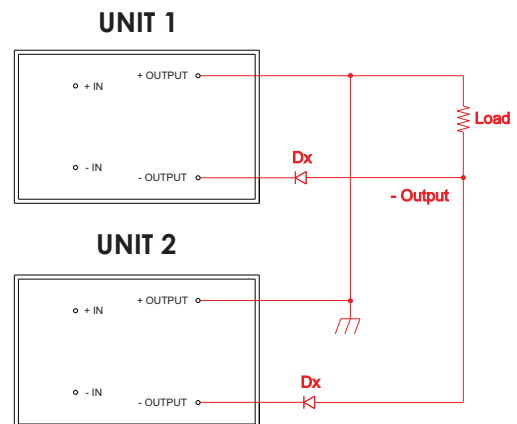

NOTE:
The ratings of Dx should be 1.5 times the maximum current and voltage expected in each branch.



P3 SERIES 3 WATT PROPORTIONAL HV DC/DC CONVERTERS

CONNECTION IN SERIES

Figures below shows how to connect multiple outputs in series with the use of shunt diodes, taking into consideration that the highest achieved output voltage should remain below the rated isolation voltage.

POSITIVE OUTPUT

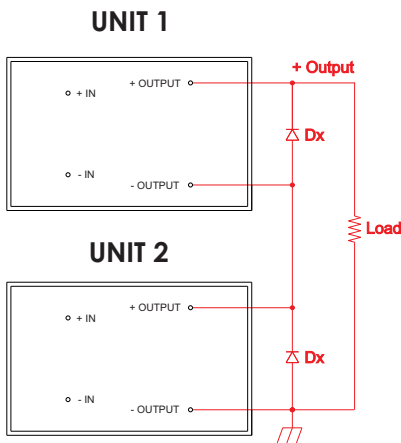

NEGATIVE OUTPUT

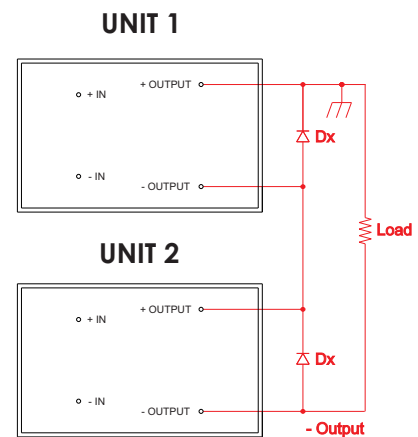

DUAL OUTPUT

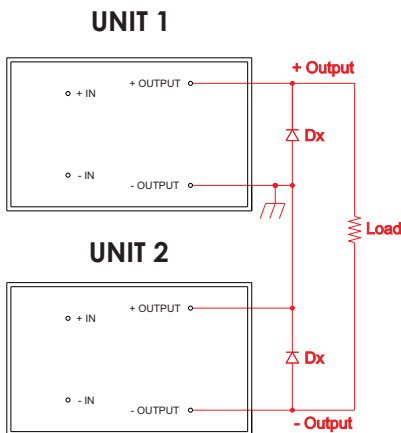

NOTE:
The ratings of Dx should be 1.5 times the maximum current and voltage expected in each branch.



P3 SERIES 3 WATT PROPORTIONAL HV DC/DC CONVERTERS

APPLICATION NOTES

POSITIVE OR NEGATIVE OUTPUTS

Isolated DC-DC voltage converters can provide positive or negative voltages from a single device.

Isolated DC-DC converters may also be used with either a positive or a negative input voltage source, as long as the relative polarity of the input to the device is maintained.

The figures below show the various polarity combinations and how to connect the converter to provide them relative to ground.

CONNECTIONS FOR DUAL OUTPUTS

Isolation on a dual output converter is from Com output pin (5) and -Input (2) and therefore ground connection on the output is to Com pin only.

The figures below shows how to power a dual output converter with either a positive or a negative input voltage source.

POSITIVE SOURCE WITH A POSITIVE OUTPUT

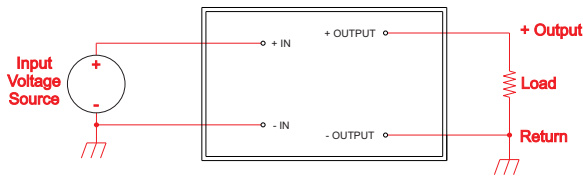

POSITIVE SOURCE WITH A NEGATIVE OUTPUT

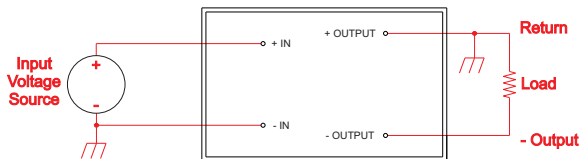

NEGATIVE SOURCE WITH A POSITIVE OUTPUT

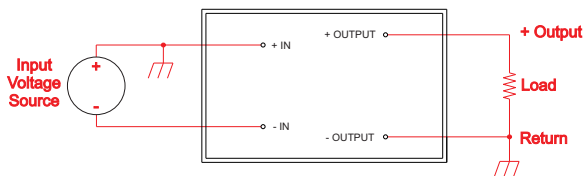

NEGATIVE SOURCE WITH A NEGATIVE OUTPUT

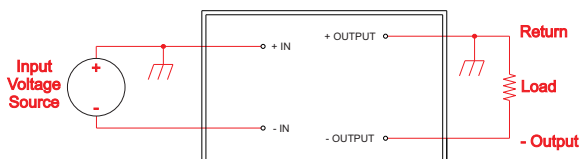

POSITIVE VOLTAGE SOURCE

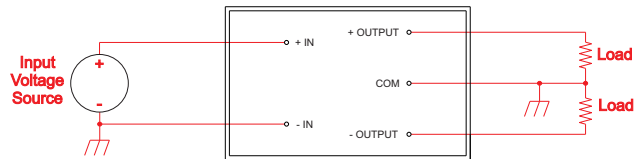

NEGATIVE VOLTAGE SOURCE

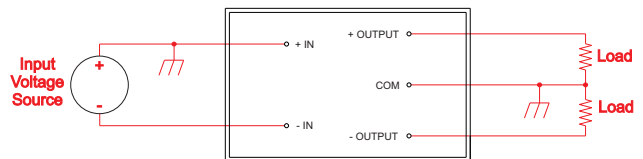

NOTE:

The (- In) must be kept negative with respect to the (+In) pin. If this polarity is reversed, permanent damage to the converter may occur.



P3 SERIES 3 WATT PROPORTIONAL HV DC/DC CONVERTERS

APPLICATION NOTES

CLEANING AGENTS

In order to avoid possible damage, any penetration of cleaning fluids must be prevented, since the power supplies are not hermetically sealed.

NUCLEAR AND MEDICAL APPLICATIONS

American Power Design products are not designed, intended for use in, or authorized for use as critical components in life support systems, equipment used in hazardous environments, or nuclear control systems without the express written consent of American Power Design, Inc.

TECHNICAL REVISIONS

The appearance of products, including safety agency certifications pictured on labels, may change depending on the date manufactured. Specifications are subject to change without notice.

SAFETY REQUIREMENTS

The converters are designed to meet North American and International safety regulatory requirements per UL 60950-1/CSA 22.2 No. 60950-1-07 Second Edition, IEC 60950-1:2005, and EN 60950-1:2006. Basic Insulation is provided between input and output. To comply with safety agencies requirements, an input line fuse must be used external to the converter. The table below provides the recommended fuse rating for use with this family of products.

| Input Voltage Range | Fuse Rating |
|---------------------|-------------|
| 0-12Vdc | 0.5A |
| 0-15Vdc | 0.5A |

If one input fuse is used for a group of modules, the maximum fuse rating should not exceed 10A.

WARRANTY

All products manufactured by American Power Design, Inc. (APD) are warranted to be free of defects due to material or workmanship for a period of one year from date of shipment. At our option, APD will repair or replace any non-conforming product.

APD expressly disclaims any liability for consequential or incidental damages resulting from the use or misuse of its products by the purchaser or others.

This warranty is in lieu of all warranties expressed or implied, including the warranties of merchantability. No other warranties, obligations, or liabilities are expressed or implied.

All products being returned for repair require a return material authorization(RMA) assigned by APD prior to return shipment.