



M30 SERIES 30 WATT PROGRAMABLE DC/DC CONVERTERS

FEATURES

- ▶ **Customer Selects Output Voltage**
- ▶ Outputs to 1000 Vdc
- ▶ Fully Programable Outputs
- ▶ Single and Dual Outputs
- ▶ Ultra Wide Input Ranges
(10-20Vdc , 18-36Vdc)
- ▶ 1500 Vdc Output Isolation
- ▶ Continuous Short Circuit Protection



The M30 Series high voltage DC/DC converter offers 100% programmable single or dual high voltage outputs using a 0-5Vdc analog signal. Each model is enclosed in a six-sided shielded metal case and has 1500Vdc of isolation allowing one model to be utilized for both positive or negative applications. All models will tolerate a short circuit indefinitely.

ELECTRICAL SPECIFICATIONS

Voltage Accuracy	+/- 3%	Input Filter	Pi Network
Line Regulation	+/- 2%	Efficiency	87% (typ.)
Load Regulation	+/- 4% (20% to full Load)	Short Circuit Protection	Continuous
Output Ripple	< 0.4 % P-P	Switching Frequency	130 kHz
Reference Voltage	5Vdc @ 1mA	Output Isolation	1500 Vdc
		Input / Output Capacitance	< 80pF

GENERAL SPECIFICATIONS

Temp. Stability	+/- 0.02%/°C	EMI/RFI	Six Sided Shield
Temp. (Operating , Case)	-25 to +70°C	Derating	None
Temp. (Storage)	-40 to +125°C	Cooling	Free-Air Convection

PHYSICAL SPECIFICATIONS

Dimensions	2.6 x 3 x 0.84 inches	Case Material	Nickel Plated Metal
Weight	8.4 Oz		(With Non-Conductive Base Plate)



M30 SERIES 30 WATT PROGRAMABLE DC/DC CONVERTERS

REPRESENTATIVE MODEL LISTING					
OUTPUT SPECIFICATIONS		MODEL NUMBER / INPUT RANGE			
VOLTAGE	CURRENT	10-20VDC		18-36VDC	
		Non-RoHs	RoHs	Non-RoHs	RoHs
0V - 48 Vdc	625 mA	M30-S48	M30-S48/Y	M30-S48/A	M30-S48/A/Y
0V - +/- 48 Vdc	312 mA	M30-D48	M30-D48/Y	M30-D48/A	M30-D48/A/Y
0V - 100Vdc	300 mA	M30-S100	M30-S100/Y	M30-S100/A	M30-S100/A/Y
0V - +/- 100Vdc	150 mA	M30-D100	M30-D100/Y	M30-D100/A	M30-D100/A/Y
0V - 150 Vdc	200 mA	M30-S150	M30-S150/Y	M30-S150/A	M30-S150/A/Y
0V - +/- 150 Vdc	100 mA	M30-D150	M30-D150/Y	M30-D150/A	M30-D150/A/Y
0V - 200 Vdc	150 mA	M30-S200	M30-S200/Y	M30-S200/A	M30-S200/A/Y
0V - +/- 200 Vdc	75 mA	M30-D200	M30-D200/Y	M30-D200/A	M30-D200/A/Y
0V - 300 Vdc	100 mA	M30-S300	M30-S300/Y	M30-S300/A	M30-S300/A/Y
0V - +/- 300 Vdc	50 mA	M30-D300	M30-D300/Y	M30-D300/A	M30-D300/A/Y
0V - 400 Vdc	75 mA	M30-S400	M30-S400/Y	M30-S400/A	M30-S400/A/Y
0V - +/- 400 Vdc	37 mA	M30-D400	M30-D400/Y	M30-D400/A	M30-D400/A/Y
0V - 500 Vdc	60 mA	M30-S500	M30-S500/Y	M30-S500/A	M30-S500/A/Y
0V - +/- 500 Vdc	30 mA	M30-D500	M30-D500/Y	M30-D500/A	M30-D500/A/Y
0V - 600 Vdc	50 mA	M30-S600	M30-S600/Y	M30-S600/A	M30-S600/A/Y
0V - 800 Vdc	37 mA	M30-S800	M30-S800/Y	M30-S800/A	M30-S800/A/Y
0V - 1000 Vdc	30 mA	M30-S1000	M30-S1000/Y	M30-S1000/A	M30-S1000/A/Y

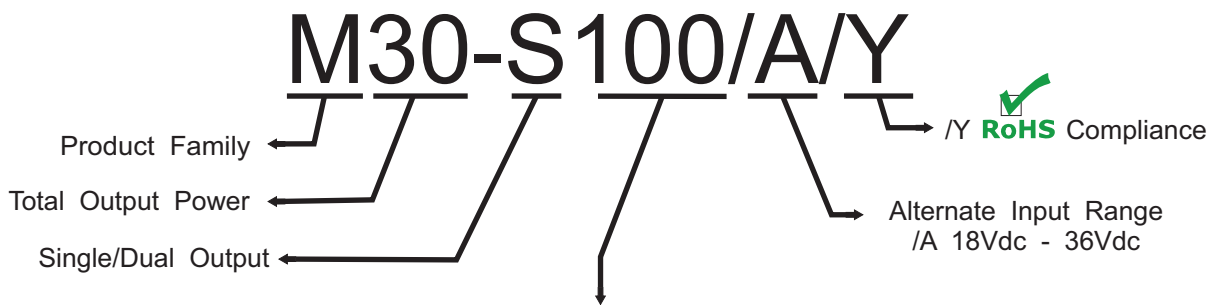

Customer Selects Output Voltage

The M30 Series are designed such that the customer may order any output voltage from 48Vdc to 1000Vdc at no additional charge.



M30 SERIES 30 WATT PROGRAMABLE DC/DC CONVERTERS

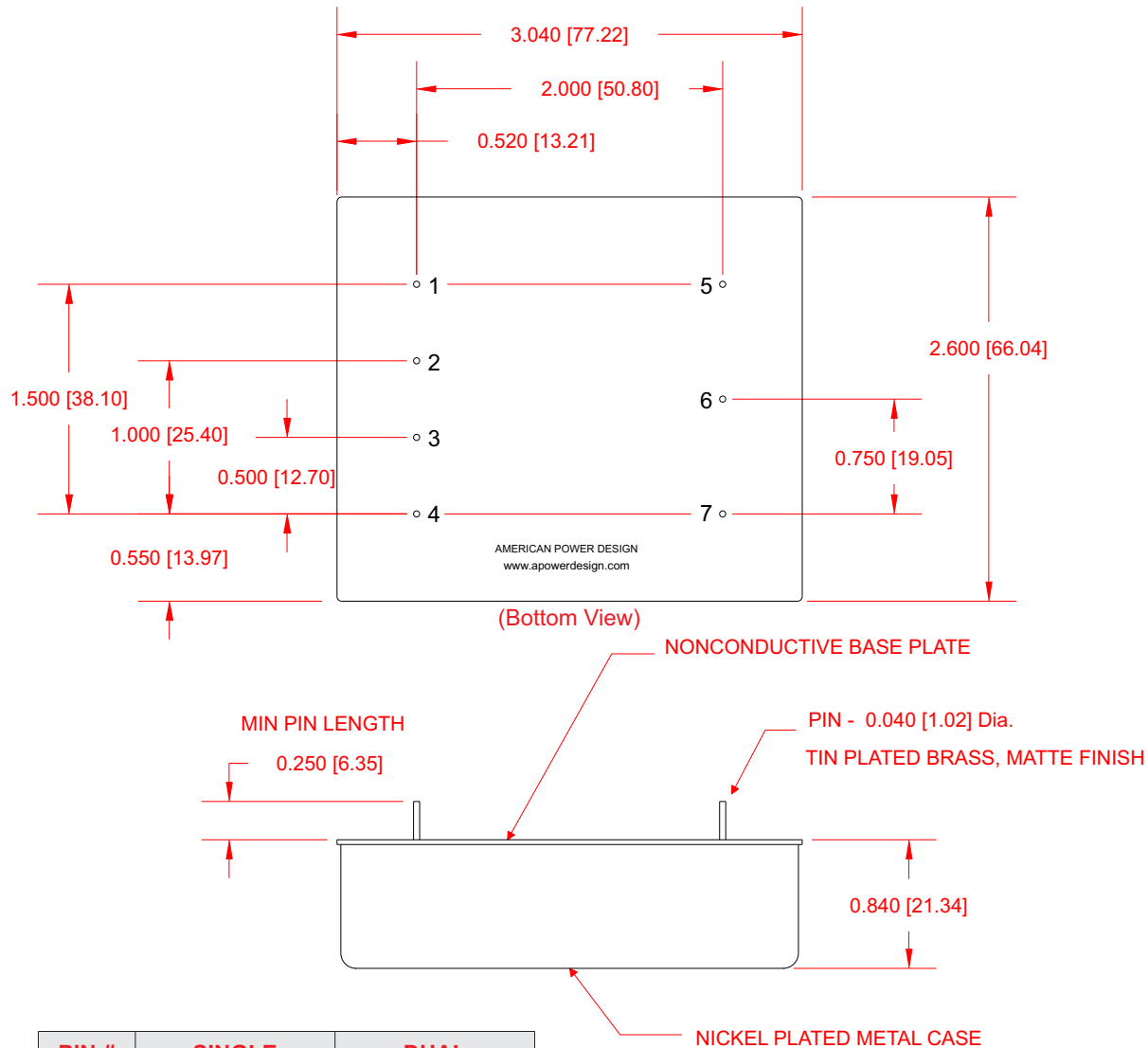

PIN #	SINGLE	DUAL
1	5V Ref	5V Ref
2	+ Input	+ Input
3	Control	Control
4	- Input	- Input
5	+ Output	+ Output
6	No Pin	Com
7	- Output	- Output

*Dimensions are in Inches
[Metric equivalents in brackets]*



M30 SERIES 30 WATT PROGRAMABLE DC/DC CONVERTERS

APPLICATION NOTES

INPUT AND OUTPUT IMPEDANCE

The M30 Series of power converters have been designed to be stable with no external capacitors when used in low inductance input and output circuits. However, in some applications, the inductance associated with the distribution from the power source to the input of the converter can affect the stability of the converter. The addition of a 100 μF electrolytic capacitor with an ESR < 1 Ohm across the input helps ensure stability of the converter. In many applications, the user has to use decoupling capacitance at the load.

SHORT CIRCUIT PROTECTION

The M30 Series is equipped with short circuit protection. The converter will fold-back the input power whenever a short circuit is applied to its output and automatically recover after the overload condition is removed.

ISOLATION

The output of the M30 Series is galvanically isolated from both the input and case, capacitance is $< 80\text{pF}$ and resistance is $> 10\text{G Ohm}$. The converters case is connected directly to -In to aid in reducing unwanted noise.

RIPPLE AND NOISE

Figure below shows a typical output voltage ripple waveform, measured at full rated load current with no additional output filtering. External low ESR capacitors may be added across output to further reduce ripple.

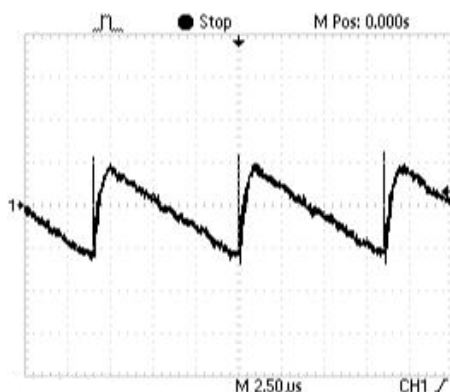

STARTUP TRANSIENT

Figure below shows a typical output voltage during turn-on, measured at 20% load current with no additional output filtering.

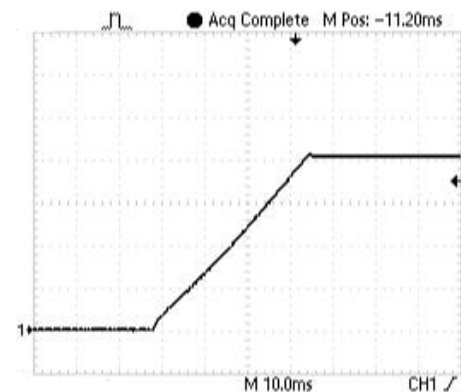
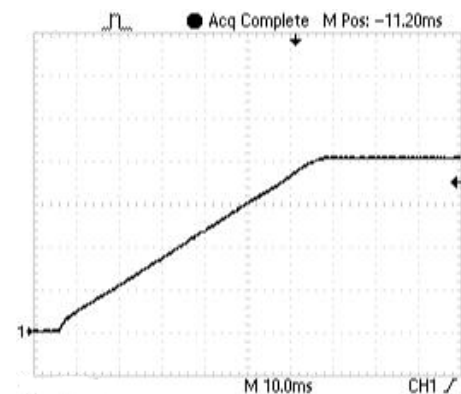

Figure below shows a typical output voltage during turn-on, measured at full rated load current with no additional output filtering.





M30 SERIES 30 WATT PROGRAMABLE DC/DC CONVERTERS

APPLICATION NOTES

INRUSH CURRENT

The inrush current of the M30 Series has been kept as low as possible. However, a series resistor may be inserted in the input line to limit this current further.

LOAD TRANSIENT

Figure below shows a typical output voltage response, measured during a transition from full rated load current to 20% load current with no additional output filtering.

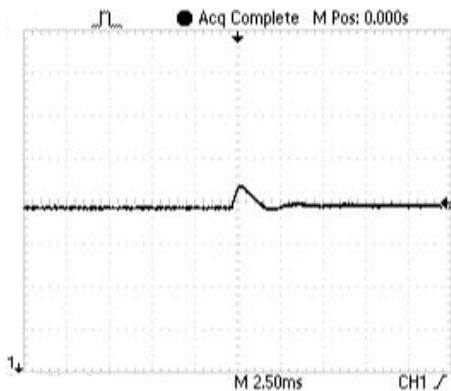
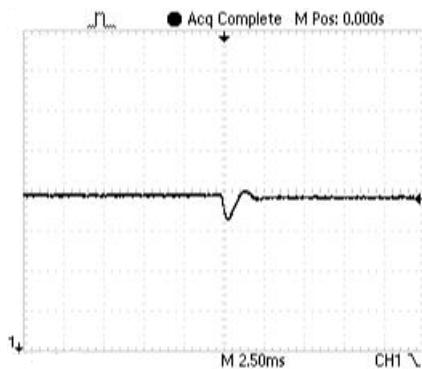
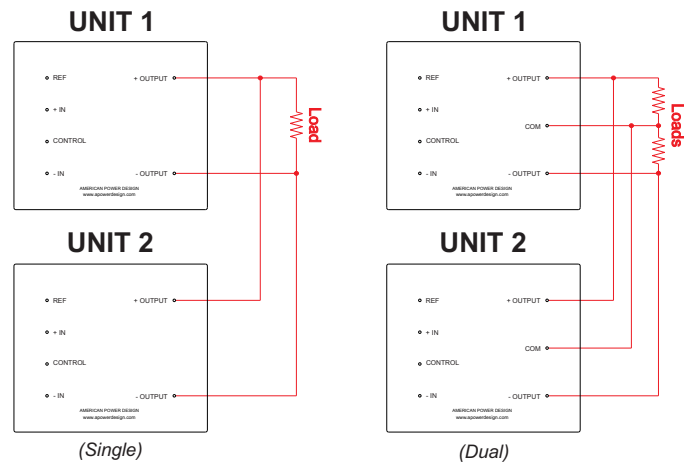

Figure below shows a typical output voltage response, measured during a transition from 20% load current to full rated load current with no additional output filtering.



CONNECTION IN PARALLEL

The figures below show how to connect both single and dual outputs of several units with equal nominal output voltage in parallel.



CONNECTION IN SERIES

The figures below show how to connect multiple outputs in series with the use of shunt diodes, taking into consideration that the highest achieved output voltage should remain below the rated isolation voltage.

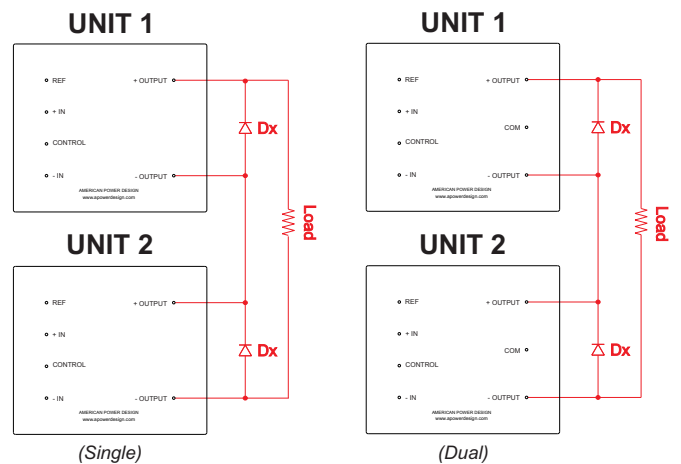

NOTE:
The ratings of Dx should be 1.5 times the maximum current and voltage expected in each branch.



M30 SERIES 30 WATT PROGRAMABLE DC/DC CONVERTERS

APPLICATION NOTES

Remote Control

The M30 Series is equipped with an output Control pin (Pin 3). This feature allows the user to adjust the output voltage from 0 to 100% of the rated output voltage using a fixed precision resistor or adjustable trim pot in conjunction with the on board reference (Pin 2).

The figure below shows how to adjust the output voltage using a fixed precision resistor.

Control Voltage can be calculated by:

$$V_{control} = 5 \times \frac{R2}{R1 + R2}$$

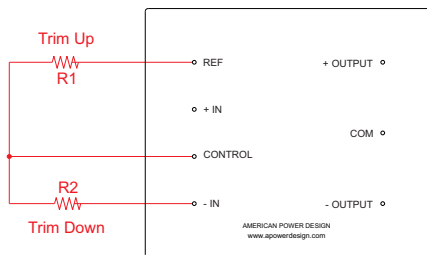

NOTE:
Do not exceed 1mA when selecting R1 & R2.

The figure below shows how to adjust the output voltage using an external Trim Pot.

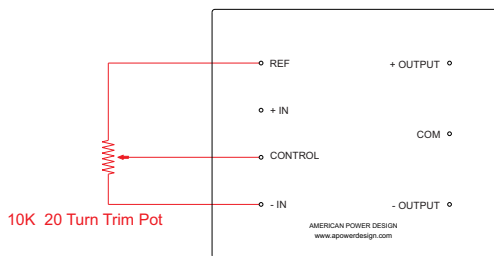

The figure below shows how to combine both of the prior configurations to form upper and lower boundaries for the adjustable range.

$$Upper\ Limit = \frac{5 \times (R2 + 10k)}{R1 + R2 + 10k}$$

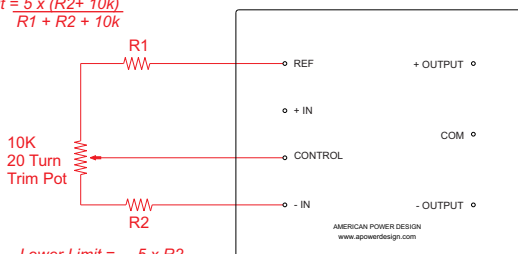

$$Lower\ Limit = \frac{5 \times R2}{R1 + R2 + 10k}$$

Figure below shows how to remotely mechanically shutdown the converter while maintaining any preset control voltage.

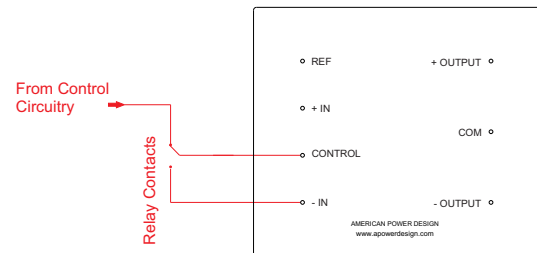

Output Voltage Tracking

The M30 Series is a semi-regulated converter and as a result there are many factors that affect the way the output voltage tracks the Control pin (Pin 3). Input regulation and load current are two of the primary influences.

Figure below show a typical plot of both the actual and calculated output voltage as a function of control voltage.

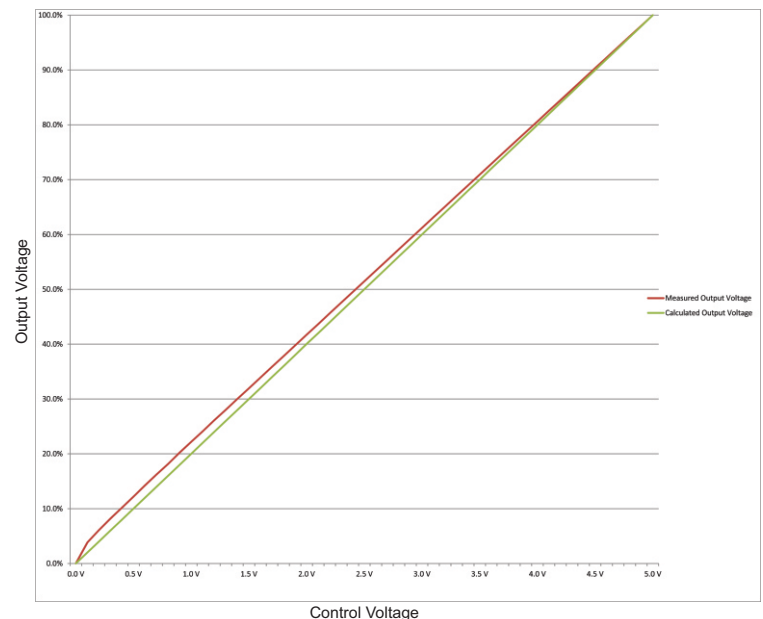

Operating Conditions:

Nominal Input Voltage = Fixed

Output Load = Resistive (fixed at full output current @ 100% output voltage)



M30 SERIES 30 WATT PROGRAMABLE DC/DC CONVERTERS

APPLICATION NOTES

CLEANING AGENTS

In order to avoid possible damage, any penetration of cleaning fluids must be prevented, since the power supplies are not hermetically sealed.

NUCLEAR AND MEDICAL APPLICATIONS

American Power Design products are not designed, intended for use in, or authorized for use as critical components in life support systems, equipment used in hazardous environments, or nuclear control systems without the express written consent of American Power Design, Inc.

TECHNICAL REVISIONS

The appearance of products, including safety agency certifications pictured on labels, may change depending on the date manufactured. Specifications are subject to change without notice.

SAFETY REQUIREMENTS

The converters are designed to meet North American and International safety regulatory requirements per UL 60950-1/CSA 22.2 No. 60950-1-07 Second Edition, IEC 60950-1:2005, and EN 60950-1:2006. Basic Insulation is provided between input and output. To comply with safety agencies requirements, an input line fuse must be used external to the converter. The table below provides the recommended fuse rating for use with this family of products.

Input Voltage Range	Fuse Rating
10-20Vdc	5A
18-36Vdc	3A

If one input fuse is used for a group of modules, the maximum fuse rating should not exceed 10A.

WARRANTY

All products manufactured by American Power Design, Inc. (APD) are warranted to be free of defects due to material or workmanship for a period of one year from date of shipment. At our option, APD will repair or replace any non-conforming product.

APD expressly disclaims any liability for consequential or incidental damages resulting from the use or misuse of its products by the purchaser or others.

This warranty is in lieu of all warranties expressed or implied, including the warranties of merchantability. No other warranties, obligations, or liabilities are expressed or implied.

All products being returned for repair require a return material authorization(RMA) assigned by APD prior to return shipment.